

Welcome to the **200 Plus Quick Start Guide**. These simple instructions will help you accomplish basic tasks on your Strand 200 Plus Console. Working in *Two Scene Mode*, *Single Scene Mode* and *Submaster Mode* are covered here (as well as a layout of the programming interface) and will help boost you toward the goal of mastering your Strand 200 Plus Console.

Two Scene Mode

Description

Separate scenes are set up on the **Preset A** and **Preset B** faders. The **A Master** and **B Master** faders are used to cross fade between the two different scenes.

How to get into Two Scene Mode

- Press the TWO SCENE button once. It will turn **yellow**
- Press the TWO SCENE button a second time. It will now turn **dark green**.
- You are now in TWO SCENE mode.

Example of operation of TWO SCENE mode with manual fading

- 1) Make sure the PRESET A MASTER and the PRESET B MASTER faders are at the top.
- 2) Set PRESET A fader [1] to 100%.
- 3) Set PRESET B fader [10] to 100%
- 4) Move the PRESET MASTER FADERS from the top to the bottom

Congratulations you have just run your first cue!

For additional tips on Two Scene Mode and how to fade between scenes using a set time. Check out timed fades on page 14 of the manual.

200 Plus Quick Start Guide

Single Scene Mode

How to get into Single Scene Mode

- Press the SINGLE SCENE button once. It will turn **yellow**
- Press the SINGLE SCENE button a second time. It will now turn **dark green**.

Description

You are able to cross fade between 48 channels (24 channels on the 12/24 model). This is completed by activating the **next** button and then using the **A Store and B Store** buttons to hold scenes set on either the **Preset A** faders or **Preset B** faders.

- You are now in SINGLE SCENE mode.

Example of operation of SINGLE SCENE mode with manual fading

- 1) Make sure the PRESET A MASTER and the PRESET B MASTER faders are at the top. This will cross fade any channels on PRESET A to 100%.
- 2) Set PRESET A faders [1], [2] & [3] to 100%.
- 3) Press the NEXT button.
- 4) Press the **A STORE** button. It will turn **red**.
- 5) Reset PRESET A faders [1], [2] & [3] to 0%.
- 6) Set PRESET B faders [4], [5] & [6] to 100%.
- 7) Move the PRESET MASTER FADERS from the top to the bottom.
 - a. You can then also store the new scene if required. To do this, follow the next steps.
- 8) Press the **B STORE** button. It will turn **red**.
- 9) Reset PRESET B faders [4], [5] & [6] to 0%.
- 10) Set PRESET A faders [7], [8] & [9] to 100%.
- 11) Move the PRESET MASTER FADERS from the bottom to the top.

Press **NEXT** to deactivate the holding feature after moving the preset master faders.

Congratulations you have just run three separate cues!!

To find out how to add set times to these fades check out page 17 in the manual.

200 Plus Quick Start Guide

Submaster Mode

Description

In this mode it is possible to store groups of conventional channels and then play them back individually or sequentially.

How to get into Single Scene

- Press the SUBMASTER Button once. It will turn **red**.

RECORDING a Submaster example

- 1) Go into SINGLE SCENE mode
- 2) Set faders [1], [2] & [3] to 100%.
- 3) Press **RECORD**
- 4) Select Submaster 1 by pressing the flash button below fader 1. Note: available submasters will have flashing red bump buttons.
- 5) Reset faders [1], [2] & [3] to 0%.
- 6) Set faders [4], [5] & [6] to 100%.
- 7) Press **RECORD**
- 8) Select Submaster 2 by pressing the flash button below fader 2.

Congratulations, you have just recorded two submasters.

Playing back Submasters

- 1) Set all channel faders to 0%.
- 2) Press the SUBMASTER button. It will turn **red**.
- 3) Raise fader 1 and fader 2 to 100%. Channels 1-6 will rise to their recorded levels.
- 4) Reset these channels by lowering faders 1 and 2.

200 Plus Quick Start Guide

Playing back Submasters sequentially

- 1) Move the Preset A Master and Preset B master faders to the bottom.
- 2) Go into **SUBMASTER** mode.
- 3) Press the **NEXT** button. This will turn **blue**.
- 4) The first submaster flash button will now be flashing **yellow**. Raise Preset A Master and the Preset B Master to the top. The first recorded submaster will now be outputting and the bump button will be a solid **yellow**.
- 5) The next submaster to output will now have a flashing **yellow** bump button. Lower the Preset A and Preset B master faders to the bottom. The second submaster will now be outputting instead of the first.

Find more about submaster pages, playing back submasters with times manually or sequentially and also deleting single submasters, pages of submasters of all recorded submasters.

Programming Interface

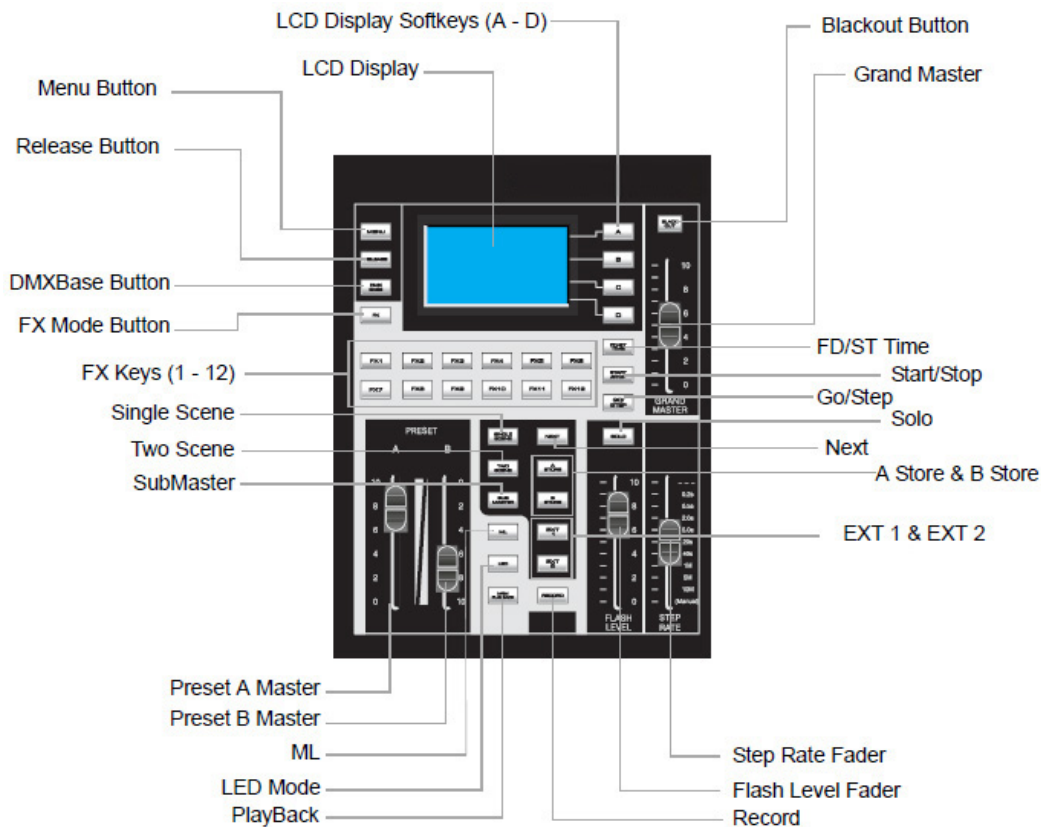

200 Plus Programming Interface